

MOM200A/600A

Microohmmeters

User's Manual



Megger

WWW.MEGGER.COM



MOM200A/600A

Microohmmeters

User's Manual

NOTICE OF COPYRIGHT & PROPRIETARY RIGHTS

© 2009, Megger Sweden AB. All rights reserved.

The contents of this manual are the property of Megger Sweden AB. No part of this work may be reproduced or transmitted in any form or by any means, except as permitted in written license agreement with Megger Sweden AB. Megger Sweden AB has made every reasonable attempt to ensure the completeness and accuracy of this document. However, the information contained in this manual is subject to change without notice, and does not represent a commitment on the part of Megger Sweden AB. Any attached hardware schematics and technical descriptions, or software listings that disclose source code, are for informational purposes only. Reproduction in whole or in part to create working hardware or software for other than Megger Sweden AB products is strictly prohibited, except as permitted by written license agreement with Megger Sweden AB.

TRADEMARK NOTICES

Megger® and Programma® are trademarks registered in the U.S. and other countries. All other brand and product names mentioned in this document are trademarks or registered trademarks of their respective companies.

Megger Sweden AB is certified according to ISO 9001 and 14001.

Megger Sweden AB
Eldarvägen 4
Box 2970
SE-187 29 TÄBY
Sweden

T +46 8 510 195 00
F +46 8 510 195 95
seinfo@megger.com
www.megger.com



Contents

1 Introduction	6
.....	6
General.....	6
Function description.....	6
2 Safety	8
.....	8
General.....	8
Symbols on the instrument	8
Safety instructions.....	8
3 Control panels	10
.....	10
Control panel for MOM200A.....	10
Control panel for MOM600A.....	11
4 Operating instructions	12
.....	12
External measuring instrument.....	13
Troubleshooting.....	13
5 Application examples	14
.....	14
Measuring resistance in a breaker	14
Measuring resistance at bus-bar joints.....	15
Expanded measuring range.....	16
Application example	16
6 Specifications	18
.....	18
Specifications MOM200A	18
Specifications MOM600A	18

1

Introduction

General

This manual is for the MOM200A, and MOM600A microohmmeters.

The microohmmeter is designed to measure the resistances of breaker contacts, bus-bar joints, contact elements in bus-bars and other high-current links.

When contact resistance rises because of oxidation, loosened or improperly tightened threaded joints, temperatures rise abnormally at the points of contact. This abnormal heating reduces conductivity thereby accelerating the rise in temperature — and this often leads to serious trouble.

The microohmmeter can be used to detect such problems early so that they can be remedied long before trouble starts. Checking contact resistance at regular intervals provides a clear indication of the state of your system.

Function description

Connect the instrument to the object being tested.

After you have adjusted the instrument to provide the desired current through the test object (100 A for example), the actual voltage drop across the test object will be measured automatically, and all you have to do is press a button to display the actual resistance.

High current is generated and sent out by the instrument during measurement. A miniature circuit breaker and a thermal cut-out are provided to make certain this current doesn't generate excessive heat inside the instrument.

The instrument is equipped with a device that guards against induction. A relay short-circuits the sensing input when the instrument's ON/OFF switch is off and also when the instrument is in the $m\Omega$ mode. To protect against external overvoltages, both the current output and the sensing input are decoupled to ground.

MOM200A is used for currents up to 200 A.

MOM600A can provide an output current of up to 600 A, and it can be set to six different measuring ranges.

Full-wave rectified current is used for measuring.

all-guides.com

2 Safety

General



Important

Read and comply with the following instructions.

Always comply with local safety regulations.

Symbols on the instrument



Caution, refer to accompanying documents.



Protective conductor terminal.



WEEE, Waste Electrical and Electronic Equipment. Please utilize your local WEEE collection facilities in the disposition of this product and otherwise observe all applicable requirements.

Safety instructions



Warning

1. Before measuring resistances in circuit breakers or disconnecting switches (isolators), always check to see that the object being tested is closed and grounded on one side.
2. If there is a current transformer in the current circuit, the protective relay equipment that is connected to it must be blocked to prevent actuation. After completing your measurements, you can follow the normal procedures that are used to demagnetize current transformer cores after DC has passed through their current transformer.
3. Never open a circuit breaker while a microohmmeter is connected to it.
4. Current continues to flow for a while after the microohmmeter is turned off. How long it continues depends on the ratio of the components in the L/R circuit.
5. Always connect protective earth (ground).
6. Always use safety connecting leads.
7. Always turn the equipment off before connecting.
8. High voltage/current on input/output terminals.
9. Never leave the instrument unattended while it is turned on and in the high current mode.
10. Unplug the instrument from the mains supply when it is left unattended or not in use.
11. Do not attempt to service the instrument yourself. Opening or removing covers may expose you to dangerous voltage. If you attempt to service the instrument yourself the warranty is no longer valid.
12. Do not use any accessories that are not intended for use together with the instrument.
13. Disconnect the instrument from the mains before cleaning. Use a damp cloth for cleaning. Do not use liquid cleaners or aerosol cleaners.



Important

1. Use only approved mains detachable cable set with the instrument. Main supply cables shall be rated for the maximum current for the equipment and the cable shall meet the requirements of IEC 60227 or IEC 60245. Mains supply cables certified or approved by a recognized testing authority are regarded as meeting this requirement.
2. Refer all servicing to authorized personnel.
3. If you need to return the instrument, please use

3 Control panels

Control panel for MOM200A

1. Positive current output (I_{OUT+})
2. Sensing terminal (SENSE)
3. Negative current output (I_{OUT-})
4. Resistance button (R)
5. Current-shunt terminal (SHUNT)
6. Miniature circuit breaker for mains (F1)
7. Miniature circuit breaker for variable transformer
8. Grounding terminal
9. ON/OFF switch
10. Mains inlet
11. LED, resistance
12. LED, current
13. LED, thermal cut-out
14. Resistance range switch
15. Current range switch
16. Variable transformer

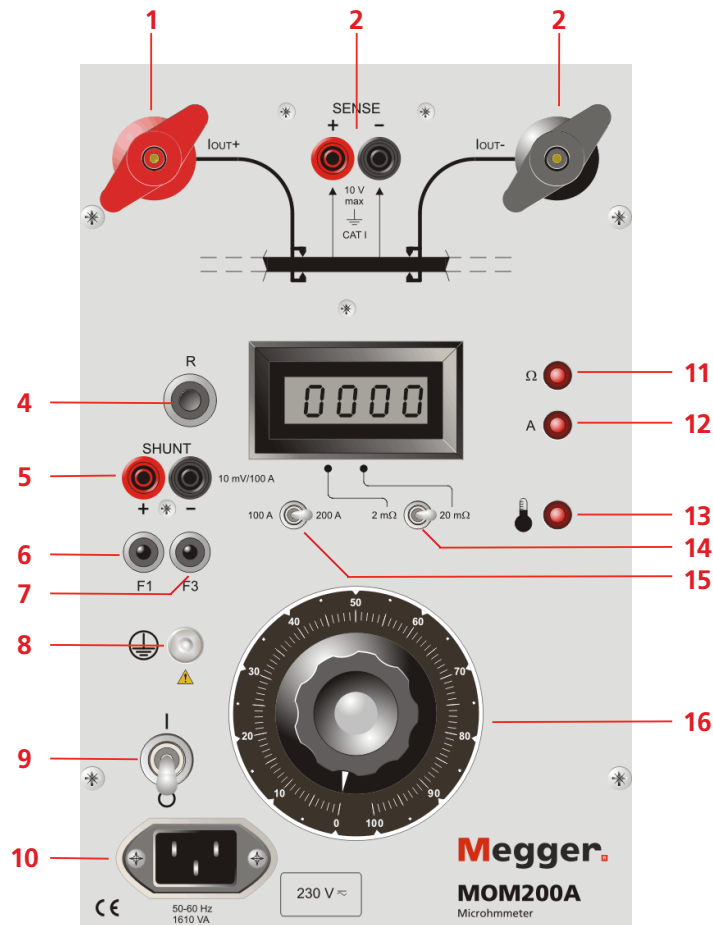

Control panel for MOM600A

1. Positive current output (I_{OUT+})
2. Sensing terminal (SENSE)
3. Negative current output (I_{OUT-})
4. Resistance button (R)
5. Sensing current push buttons
6. Current-shunt terminal (SHUNT)
7. Miniature circuit breaker for mains (F1)
8. Grounding terminal
9. Mains inlet
10. LED, resistance
11. LED, current
12. LED, thermal cut-out
13. Miniature circuit breaker, 17 A (F3, MOM600 115 V only)
14. ON/OFF switch
15. Variable transformer

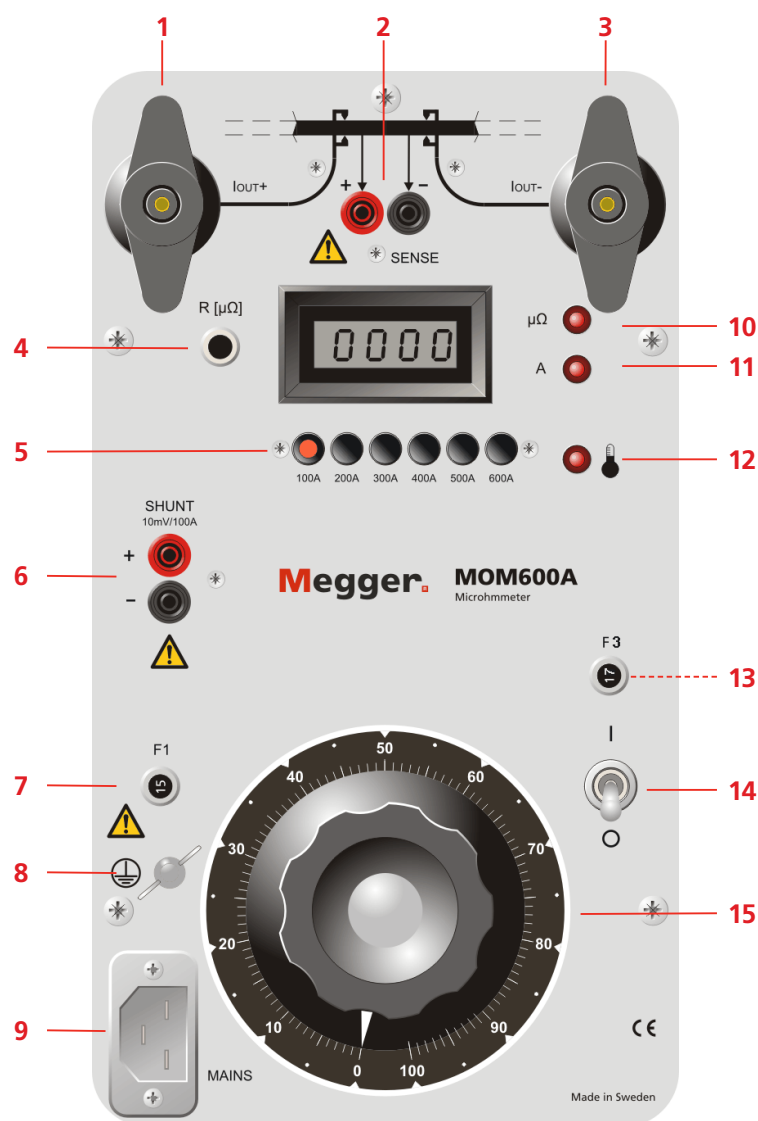

4 Operating instructions



Important

Read the manual and comply with the Safety instructions before using the microohmmeter.

Always comply with local safety regulations.

Note

Operating this equipment near sources of strong electric fields may cause it to display erroneous current values.

Since power consumption is high, the instrument requires a 16 A fuse.

On the MOM200A model, you must set the decimal point selector so that the decimal point is located correctly for the measuring range. If the display shows an "1" to the far left the current range has been exceeded

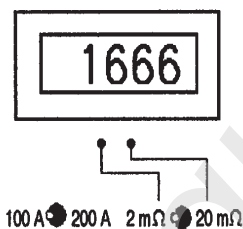

If the thermal cut-out trips (indicated by a lamp), you must wait until the instrument's temperature drops. The thermal cut-out will then be reset automatically, whereupon the microohmmeter will be ready to use again.



WARNING

Current continues to flow for a while after the microohmmeter is turned off. How long it continues depends on the ratio of the components in the L/R circuit.

- 1] Keep the microohmmeter disconnected from the mains while making connections.
- 2] Ground one side of the test object.
- 3] Ground the microohmmeter.

- 4] Connect the two current cables on two sides of the test object.
- 5] Connect the two sensing cables (using the same polarities as those used for the current cables) on two sides of the test object and as close to the test object as possible.

Note The sensing cables must be connected inside the current cables. Otherwise the test data may be incorrect. See Fig. 1.

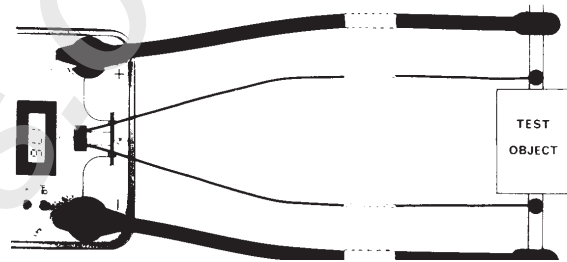

Fig. 1

- 6] Connect the microohmmeter to the mains.
- 7] Turn on the ON/OFF switch.
- 8] **MOM200A:** Select the desired current range using the "Current range switch".
MOM600A: Select the desired current range using the proper "Sensing current push button".
- 9] Clear, 0-set, the instrument by turning the knob (16) on the variable transformer down to "0", whereupon it will enter the current-generation mode and LED (12) will light up.
- 10] Now turn the knob (16) on the variable transformer to the right until the current rises to the desired value. Check the value on the digital measurement instrument. The analog instrument (on MOM 600A) provides only an approximate current reading. To obtain the best microohm reading, you should try to generate a current value as close as possible to the current that you selected with the current range switch on MOM200A or the push buttons on MOM600A.

11] Press resistance button R.

The instrument will interrupt the current flowing through the test object and enter the calculation mode. After about two seconds, the resistance reading will appear on the digital display expressed in microohms (on model MOM600A) or milliohms (on model MOM200A). The current flowing through the test object is interrupted automatically, but the reading remains visible on the display.

12] Turn off and disconnect the microohmmeter from the mains before doing any disconnection work or moving any cables or wiring.**External measuring instrument**

If, for some reason, you want to use an external measuring instrument to set the measurement current, you can connect it to the current shunt. Voltage across the current shunt is proportional to the measurement current flowing through the test object, 10 mV per 100 A.

Troubleshooting

Fault	Cause	Remedy
Display shows only a 1 at left.	Current range set on instrument has been exceeded.	If possible, select another current range. Expand the current range using the method described in section "Expanded measuring range".
	Poor contact at ends of sensing cables.	Check the sensing cable connections.
Thermal cut-out has tripped.	Overload.	Wait until the temperature drops and the light-emitting diode goes out.
Mains miniature circuit breaker has tripped	Overload or fault in instrument.	Reset the miniature circuit breaker. If it trips again, contact service personnel.

5 Application examples

Measuring resistance in a breaker



Important

Read the manual and comply with the Safety instructions before using the microohmmeter.

Always comply with local safety regulations.

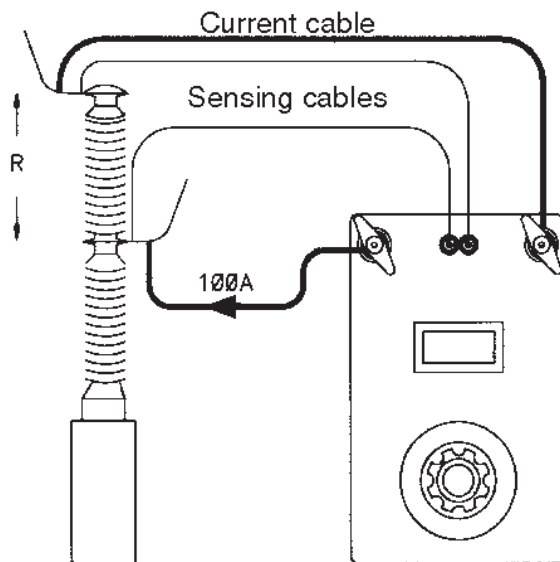

Fig. 2

- 1] Make certain the mains are de-energized on both sides of the breaker. Ground the breaker on one side and make certain it is closed.
- 2] Keep the microohmmeter disconnected from the mains while making connections.
- 3] Ground the microohmmeter.
- 4] Connect the current cables and the sensing cables (with the same polarities) on both sides of the breaker.



Important

The sensing cables must be connected inside the current cables. Otherwise the test data may be incorrect. See fig. 2.

- 5] Connect the microohmmeter to the mains.
- 6] Turn on the ON/OFF switch.
- 7] **MOM200A:** Select the desired current range (100 A for example) using the "Current range switch".
MOM600A: Select the desired current range (100 A for example) using the proper "Sensing current push button".
- 8] Clear, 0-set, the instrument by turning the knob (16) on the variable transformer down to "0", whereupon it will enter the current-generation mode and LED (12) will light up.
- 9] Increase the current as close as possible to the desired value (100 A in this case, which was the range you just selected). Set the current accurately using the digital measuring instrument. If you want to generate currents that are outside the selected measuring range, you must calculate the resistance manually as set forth in application example "Expanded measuring range" (see below).
- 10] Press resistance button R, whereupon the instrument will calculate the actual resistance and present it on the display.
- 11] Turn off and disconnect the microohmmeter from the mains before doing any disconnection work or moving any cables or wiring.

Measuring resistance at bus-bar joints



Important

Read the manual and comply with the Safety instructions before using the microohmmeter.

Always comply with local safety regulations.

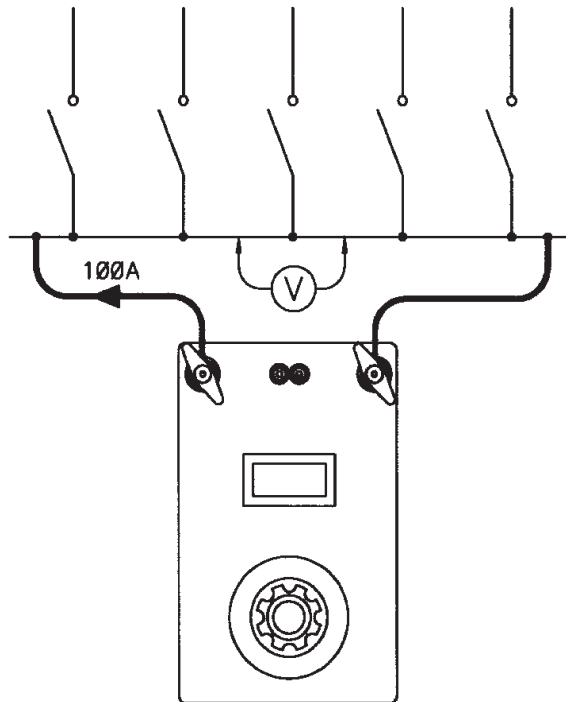

Fig. 3

- 1] Make certain the mains are de-energized and the test object is grounded.
- 2] Keep the microohmmeter disconnected from the mains while making connections.
- 3] Ground the microohmmeter.
- 4] Connect the microohmmeter's current cables to the test object, see fig. 5. Do not connect the sensing cables. Measurement will be done manually using an external portable voltmeter.
- 5] Connect the microohmmeter to the mains.
- 6] Turn on the ON/OFF switch.
- 7] **MOM200A:** Select the desired current range (100 A for example) using the "Current range switch".
MOM600A: Select the desired current range

(100 A for example) using the proper "Sensing current push button".

- 8] Clear, 0-set, the instrument by turning the knob (16) on the variable transformer down to "0", whereupon it will enter the current-generation mode and LED (12) will light up.
- 9] Increase the current as close as possible to the desired value (100 A in this case, which was the range you just selected). Set the current accurately using the digital measuring instrument.
- 10] Using an external voltmeter, measure the voltage drop (voltage) across each contact element within every section of the bus-bar being tested. The multimeter must be set to DC and to measure voltage. You must calculate the actual resistance yourself.
Example: If the voltage drop is 0.0067 V at a current of 100 A, the resistance will be $0.0067/100$ ohms, i.e. 67 microohms.
- 11] Turn off and disconnect the microohmmeter from the mains before doing any disconnection work or moving any cables or wiring.

Expanded measuring range

The measuring range can be expanded by setting the current lower than what was selected using the current range switch. Here, you must measure and calculate the resistance manually, and the accuracy is somewhat lower than normal. Application example (see below) illustrates the procedure.

Note *This procedure expands the microohmmeter's measuring range, but the accuracy drops somewhat.*

- 12]** Turn off and disconnect the microohmmeter from the mains before doing any disconnection work or moving any cables or wiring.

Application example



Important

Read the manual and comply with the Safety instructions before using the microohmmeter.

Always comply with local safety regulations.

- 1] Make certain that the mains are de-energized and that the test object is grounded.
- 2] Keep the microohmmeter disconnected from the mains while making connections.
- 3] Ground the microohmmeter.
- 4] Connect the two current cables and two sensing cables (using the same polarities) to the two sides measurement site. The sensing cables must be connected close to the test object.
- 5] Connect the microohmmeter to the mains.
- 6] Turn the instrument's ON/OFF switch ON.
- 7] Select the desired current range (400 A for example) using the sensing current push buttons on the MOM600A.
- 8] Clear, 0-set, the instrument by turning the knob (16) on the variable transformer down to "0", whereupon it will enter the current-generation mode and LED (12) will light up.
- 9] Increase the current as close as possible to the desired value (100 A in this case). Set the current accurately using the digital measuring instrument.
- 10] Press resistance button R. The instrument will do the calculation and present an incorrect resistance reading.
- 11] To obtain the correct resistance reading you must multiply the displayed reading by a factor of X. To obtain X, divide the selected current range by the generated current.
Example: $400/100 = 4$.

all-guides.com

6 Specifications

Specifications MOM200A

Specifications are valid at nominal input voltage and an ambient temperature of +25°C, (77°F). Specifications are subject to change without notice.

Environment

Application field The instrument is intended for use in high-voltage substations and industrial environments.

Temperature

Operating 0°C to +50°C (32°F to +122°F)

Storage & transport -40°C to +70°C (-40°F to +158°F)

Humidity 5% – 95% RH, non-condensing

CE-marking

LVD 2006/95/EC

EMC 2004/108/EC

General

Mains voltage 115/230 V AC, 50/60 Hz

Power consumption 1610 VA (max)

Protection Miniature circuit breakers, thermal cut-outs

Dimensions

Instrument 280 x 178 x 246 mm (11" x 7" x 9.7")

Transport case 560 x 260 x 360 mm
(22" x 10.2" x 14.2")

Weight 14.6 kg (32.2 lbs) 26 kg (54.1 lbs)
with accessories and transport case

Current cables 2 x 5 m (16 ft), 25 mm²

Sensing cables 2 x 5 m (16 ft), 2.5 mm²

Measurement section

Resistance

Range 0 – 1999 μΩ
0 – 19.99 mΩ

Resolution 1 μΩ
10 μΩ

Inaccuracy ±1% of reading + 1 digit

Output

Current 0 – 200 A DC

Open circuit voltage 4.7 V DC

Current shunt output 10 mV/100 A ±0.5%, max 20 mV out, max 10 V to protective earth (ground)

Max. load capacity

Current adjustment set to 100%

Output current	Min. output voltage	Max. load time	Rest time	Input current at 115/230 V AC
100 A DC	3.8 V DC	5 min. 15 min.	15 min. 60 min.	–
200 A DC	3.0 V DC	20 s	5 min.	14 A/7 A

Specifications MOM600A

Specifications are valid at nominal input voltage and an ambient temperature of +25°C, (77°F). Specifications are subject to change without notice.

Environment

Application field The instrument is intended for use in high-voltage substations and industrial environments

Temperature

Operating 0°C to +50°C (32°F to +122°F)

Storage & transport -40°C to +70°C (-40°F to +158°F)

Humidity 5% – 95% RH, non-condensing

CE-marking

LVD 2006/95/EC

EMC 2004/108/EC

General

Mains voltage 115/230 V AC, 50/60 Hz

Power consumption (max) 115 V, 4370 VA
230 V, 7360 VA

Protection Miniature circuit breakers, thermal cut-outs

Dimensions

Instrument 356 x 203 x 241 mm (14" x 8" x 9.5")

Transport case 610 x 290 x 360 mm
(24.0" x 11.4" x 14.2")

Weight, 115 V model 25 kg (55.1 lbs)
43.1 kg (95 lbs) with accessories and transport case

Weight, 230 V model 24.7 kg (54.5 lbs), 42.8 kg (94.4 lbs)
with accessories and transport case

Current cables 2 x 5 m (16 ft), 50 mm²

Sensing cables 2 x 5 m (16 ft), 2.5 mm²

Measurement section

Resistance

Range 0 – 1999 μΩ

Resolution 1 μΩ

Inaccuracy ±1% of reading + 1 digit
(at 100 – 600 A test current)

Output, 115 V model

Current 0 – 600 A DC

Open circuit voltage 5.2 V DC

Current shunt output 10 mV/100 A ±0.5%, max 60 mV out, max 10 V to protective earth (ground)

Output, 230 V model

Current 0 – 600 A DC

Open circuit voltage 9 V DC

Current shunt output 10 mV/100 A ±0.5%, max 60 mV out, max 10 V to protective earth (ground)

Max. load capacity, 115 V model

Current adjustment set to 100%

<i>Output current</i>	<i>Min. output voltage</i>	<i>Max. load time</i>	<i>Rest time</i>	<i>Input current</i>
100 A DC	4.6 V	-	-	8 A
300 A DC	3.8 V	1.5 min.	15 min.	20 A
600 A DC	2.6 V	10 s	5 min.	38 A

Max. load capacity, 230 V model

Current adjustment set to 100%

<i>Output current</i>	<i>Min. output voltage</i>	<i>Max. load time</i>	<i>Rest time</i>	<i>Input current</i>
100 A DC	8.3 V	-	-	6 A
300 A DC	7.2 V	2.5 min.	15 min.	16 A
600 A DC	5.6 V	15 s	5 min.	32 A

Your "One Stop" Source for all your electrical test equipment needs

- Battery Test Equipment
- Cable Fault Locating Equipment
- Circuit Breaker Test Equipment
- Data Communications Test Equipment
- Fiber Optic Test Equipment
- Ground Resistance Test Equipment
- Insulation Power Factor (C&DF) Test Equipment
- Insulation Resistance Test Equipment
- Line Testing Equipment
- Low Resistance Ohmmeters
- Motor & Phase Rotation Test Equipment
- Multimeters
- Oil Test Equipment
- Portable Appliance & Tool Testers
- Power Quality Instruments
- Recloser Test Equipment
- Relay Test Equipment
- T1 Network Test Equipment
- Tachometers & Speed Measuring Instruments
- TDR Test Equipment
- Transformer Test Equipment
- Transmission Impairment Test Equipment
- Watthour Meter Test Equipment
- STATES® Terminal Blocks & Test Switches
- Professional Hands-On Technical and
- Safety Training Programs

Megger is a world leading manufacturer and supplier of test and measurement instruments used within the electric power, building wiring and telecommunication industries.

With research, engineering and manufacturing facilities in the USA, UK and Sweden, combined with sales and technical support in most countries, Megger is uniquely placed to meet the needs of its customers worldwide.

For more information about Megger and its diversified line of test and measurement instruments: www.megger.com

Megger is certified according to ISO 9001 and 14001.

Megger is a registered trademark

Megger[®]